

## DATASHEET



The Orion<sup>®</sup> 935DX is a High Performance dual view X-Ray system for Air Cargo and pallet screening. Featuring a modular low conveyor system and a central under conveyor generator for the primary view, the Orion Suite continues to re-imagine X-Ray Screening with the best in class image quality available.

BEST IN CLASS IMAGE QUALITY

CENTRAL UNDER BELT GENERATOR

ADVANCED OPERATOR ASSIST TOOLS

SCALABLE MODULAR DESIGN

EC  
300/2008  
COMPLIANT

### MODULAR DESIGN

The 935DX modular design facilitates an unprecedented ease of installation and flexibility into new and existing facilities with the flexibility to adapt to meet your ever changing operational requirements. Optional accessories include extended conveyors and extended shrouds for enhanced performance and radiation protection.

### THREAT DETECTION AND SCANAI

ScanAI offers a range of regulated and unregulated AI solutions designed for fast and accurate detection of various prohibited items including Dangerous Goods such as Lithium Ion Batteries.

Target and NARCScan are designed to detect a wide range of explosives and narcotics respectively in real time during the scanning process by marking a potential threat on the X-ray image. Rapiscan<sup>®</sup> Systems detection algorithms are based on regulatory approved material analysis techniques.

### BEST IN CLASS IMAGE

Potential threats are becoming increasingly challenging to identify. ORION<sup>®</sup> with ScanOS was purpose-built to improve visibility during the screening process helping operators identify and mitigate potential threats faster by leveraging innovative features including:

#### CENTRAL UNDER BELT GENERATOR

By positioning the primary generator centrally under the conveyor the X-Ray source is close to the screening objects providing natural magnification. Coupled with the U Shaped detector line this creates an extremely accurate image of the objects scanned which are then presented to the operator with the correct aspect ratio regardless of orientation and position on the belt.

### INTELLIGENT DESIGN

Specifically created to work in many challenging environments, the 935DX has been intelligently designed with no service access required from the top so it can be installed in facilities with space constraints such as low ceilings.

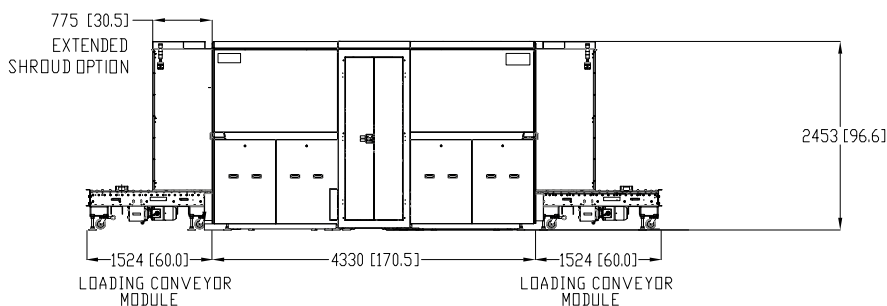
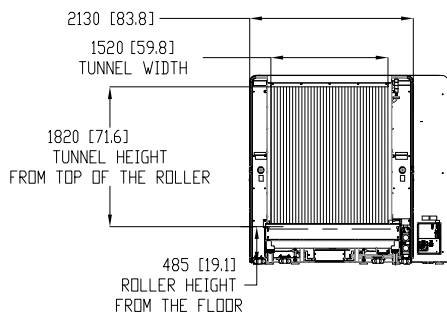

### PHYSICAL SPECIFICATIONS

DIMENSIONS	L	4,330 mm (170.5 in)
	W	2,589 mm (102.0 in)
	H	2,453 mm (96.6 in)
TUNNEL SIZE	W	1,520 mm (60.0 in)
	H	1,820 mm (71.7 in)
CONVEYOR LOAD (MAX)		1,000 kg (2204.62 lbs) per meter
CONVEYOR HEIGHT		485 mm (19.1 in)
GROSS WEIGHT		9,570 kg (21098.2 lbs)
NET WEIGHT		7,800 kg (17196.1 lbs)
SYSTEM POWER		240 VAC ±10% 50/60Hz

### X-RAY GENERATOR

VOLTAGE	Vertical	300kV
	Horizontal	200kV
		Digitally Configurable
ORIENTATION		Centrally Upward & Diagonally from Side

### ENVIRONMENT & POWER

STORAGE TEMPERATURE	-20°C to 50°C
OPERATING TEMPERATURE	0°C to 40°C
RELATIVE HUMIDITY	5 to 95% non-condensing
SYSTEM POWER	100/110/120/200/208 /220/230/240 VAC ±10% 50Hz / 60 Hz ±3%
POWER CONSUMPTION	Approx. 3.6 kW

### STANDARD SPEED PERFORMANCE<sup>1</sup>

CONVEYOR SPEED	0.20 m/sec (39.4 ft/min)
STEEL PENETRATION	70 mm Vertical View, 50 mm Horizontal View
WIRE RESOLUTION	36 AWG typical, 32 AWG standard
SPATIAL RESOLUTION	1.0 mm (0.04 in) Vertical / Horizontal

### CONFIGURATION OPTIONS

LOADING CONVEYORS	Powered Entry & Exit Extensions End Stops
EXTENDED SHROUDS	Enhanced Radiation Protection Light Parcel Screening

### KEY FEATURES

- ScanOS 64-bit Operating System
- Geometric Distortion Correction
- DICOS Image Format
- Advanced Image Processing Tools
- Dual Mode Z-effective
- Modular Design
- Multilingual Support

### KEY OPTIONS

- Extended Conveyors
- Extended Shrouds
- Threat Image Projection
- Explosive threats, narcotics & density alerts
- BHS / System Integration:
  - Standard Open Interface Capability
- ScanAI Capable:
  - ScanAI Lithium ION Battery
- ScanORIGIN Capable:
  - Remote Archive Review
  - Multi-System Alarm Resolution
  - Multiplexing / Matrixing
  - Remote Status Monitoring



sales@rapiscansystems.com

www.rapiscansystems.com



**Rapiscan**  
systems  
An OSI Systems Company

1. Stated performance as measured by Rapiscan® Imaging Validation Test Kit. Rapiscan reserves right to amend specifications.

Rapiscan® Systems is ISO 9001:2015 Certified

Rapiscan® Systems' cabinet X-ray products are designed to meet all applicable Laws and regulations with respect to X-Ray devices, contained in the cabinet X-ray radiation safety performance standard [21 CFR 1020.40] and the general performance standard [21 CFR Part 1010] as well as IEC standard 61010-2-091. Rapiscan® baggage and parcel inspection systems radiation emission leakages are well below the required regulatory limits with applicable laws & regulations on all surfaces of cabinet X-ray.

With continual development of our products Rapiscan® Systems reserves the right to amend specifications without notice. Product pictures are for general reference. Please note that due to US laws and regulations, not all Rapiscan® products are available for sale in all countries without restriction. Please contact your Rapiscan® Systems sales representative for more information.